

NOTES:

1. MATERIAL:
 - 1.1 HOUSING: THERMOPLASTIC, HIGH TEMP., UL94V-0; COLOR:BLACK.
 - 1.2 CONTACT: COPPER ALLOY
 - 1.3 FITTING NAIL: COPPER ALLOY
2. FINISH:
 - 2.1 CONTACT:50~100u" NICKEL UNDERPLATING OVERALL. 1:1u"~3u" MIN GOLD FLASH PLATING OVERALL. N:100u"~200u" MATT TIN OVERALL,
 - 2.2 FITTING NAIL:50~100u" NICKEL UNDERPLATING OVERALL. 1:1u"~3u" GOLD FLASH PLATING OVERALL. N:100u"~200u" MATT TIN OVERALL.
3. REFLOW SOLDER CAPABLE TO 260°C PER ACES SPEC.
4. SPEC. PLS. REFER TO PS-50054-XXXXX-XXX
5. PACKAGE PLS. REFER TO 88075-XXXX(-U)-TRP
6. PART NUMBER

P/N LEGEND

50054-XXX X X-XXX

NO OF CKT

XXX	Housing Color	PACKAGE	Halogen Free
001	Black	88075-XXXX-TRP	HF
S01	Black	88075-XXXX-U-TRP	HF

PACKING

- 1:TUBE PACKAGE
- 0:TAPE & REEL
- 8:TUBE PACKAGE WITH COVER
- 7:TAPE & REEL WITH COVER:MATT TIN(LEAD FREE)

PLATING

- 1:GOLD FLASH OVERALL

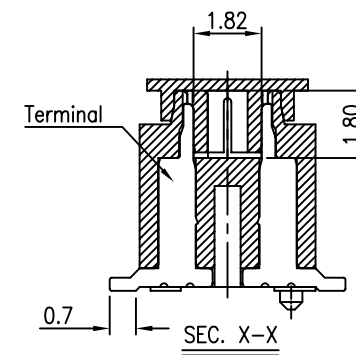

CKT	Dim A	Dim B	Dim C
10	2.0	7.1	6.1
14	3.0	8.1	7.1
16	3.5	8.6	7.6
20	4.5	9.6	8.6
24	5.5	10.6	9.6
30	7.0	12.1	11.1
34	8.0	13.1	12.1
40	9.5	14.6	13.6
50	12.0	17.1	16.1
60	14.5	19.6	18.6
160	39.5	44.6	43.6

一般公差 TOLERANCES X ±0.5 XX ±0.15 X ±0.25 XXX ±0.1 ANGLES ±2°		宏致電子股份有限公司 Aces Electronic Co.,Ltd.	
檢驗尺寸標示 SYMBOLS ⊕ ⊕ INDICATE CLASSIFICATION DIMENSION ⊕ MARK IS CRITICAL DIM. ⊕ MARK IS MAJOR DIM. 表面處理 (FINISH)	品名 (TITLE) 0.5mm BTB D/R CONN. SMT S/T TYPE 圖號 (DWG.NO) 50054-XXXXX-XXX 比例 (SCALE) 單位 (UNITS) 5:1 mm	製圖 (DR) LZ 11/05/04 審核 (CHKD) CARL 核准 (APPD) Jason	張數 (SHEET) 10F 1 SIZE A4 REV A